

MILITARY COTS DC-DC CONVERTER

155-425V Continuous Input	155-475V Transient Input	10-40V Output	1KW/60A Output	94% @ 500W / 92% @ 1KW Efficiency
-------------------------------------	------------------------------------	-------------------------	--------------------------	---

Operation: -55°C to +100°C

The MilQor® series of Mil-COTS DC-DC converters brings SynQor's field proven high-efficiency synchronous rectification technology to the Military/Aerospace industry. SynQor's ruggedized encased packaging approach ensures survivability in demanding environments. Compatible with the industry standard format, these converters operate at a fixed frequency, and follow conservative component derating guidelines. They are designed and manufactured to comply with a wide range of military standards.

MilCOTS™



Designed and Manufactured in the USA

Control Features

- No maximum external output capacitance requirement
- Fully Isolated On/Off control
- Remote sense for the output voltage
- Wide range output voltage selection
- Active current sharing
- Clock synchronization
- Serial communication

Safety Features

- 4250V dc, 100 MΩ input-to-output isolation
- (see Standards and Qualifications page)

Mechanical Features

- Industry standard full-brick pin-out configuration
- Size: 4.686" x 2.486" x 0.512"
119.0 x 63.1 x 13.0 mm
- Total weight: 10.2oz (289g)
- Flanged baseplate version available

Specification Compliance

MCOTS series converters (with an MCOTS filter) are designed to meet:

- MIL-HDBK-704 (A-F)
- MIL-STD-461 (C, D, E, F)

Operational Features

- High efficiency, 92% at full rated load current
- Operating input voltage range: 155-425 V
- Fixed frequency switching provides predictable EMI

Protection Features

- Input under-voltage lockout/over-voltage shutdown
- Output current limit and short circuit protection
- Input over-voltage protection
- Output over-voltage protection
- Thermal shutdown
- Battle Short protection

Screening/Qualification

- AS9100 and ISO 9001 certified facility
- Qualified to MIL-STD-810
- Available with S-Grade or M-Grade screening
- Pre-cap inspection per IPC-A-610, Class III
- Temperature cycling per MIL-STD-883, Method 1010, Condition B, 10 cycles
- Burn-In at 100 °C baseplate temperature
- Final visual inspection per MIL-STD-883, Method 2009
- Full component traceability

Technical Specification

BLOCK DIAGRAM

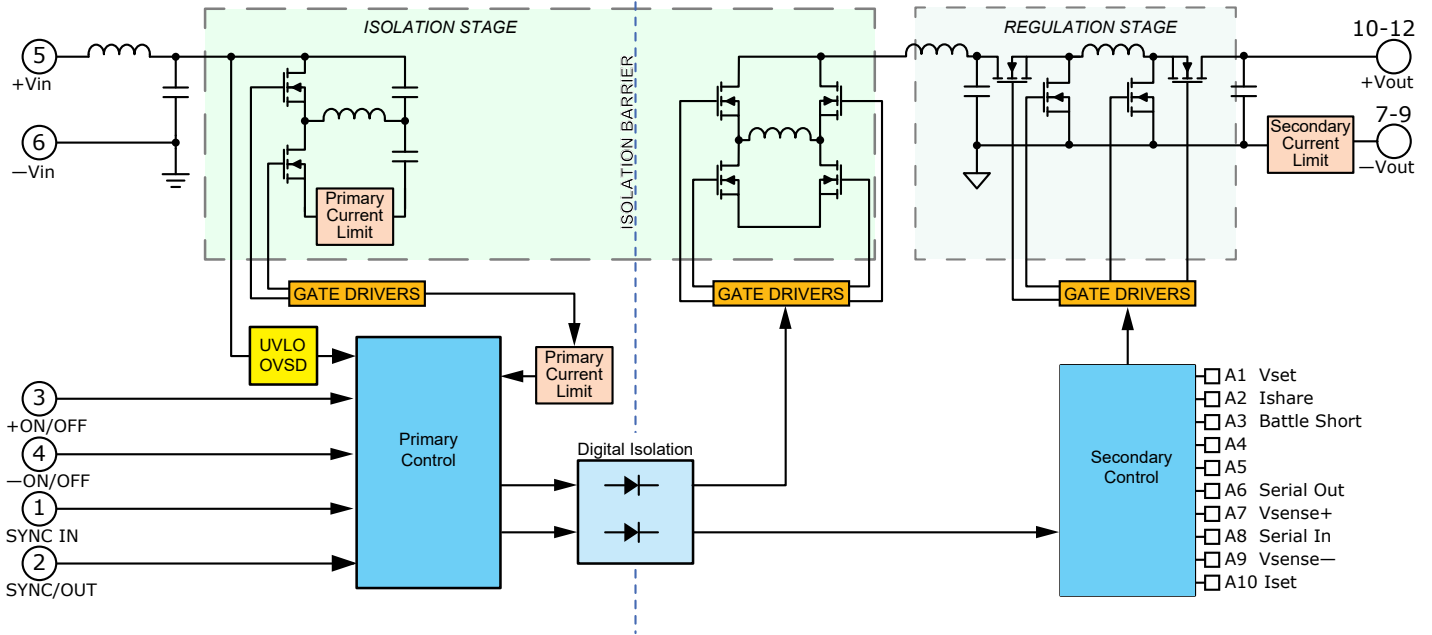

TYPICAL CONNECTION DIAGRAM

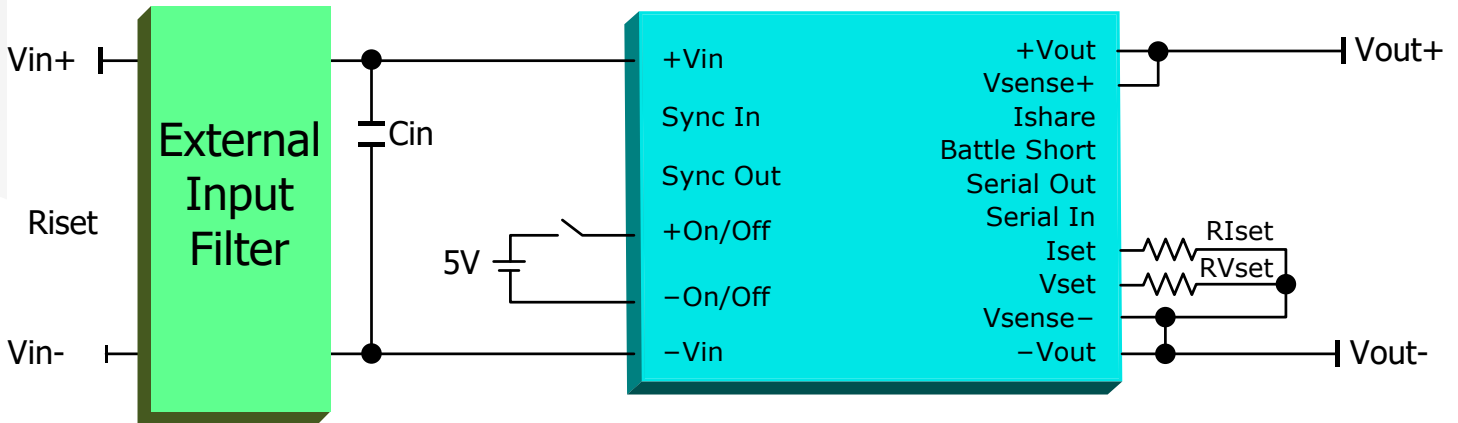

Technical Specification

MCOTS-C-270-40-FE ELECTRICAL CHARACTERISTICS

Tb = 25 °C, Vin = 270dc unless otherwise noted; full operating temperature range is -55 °C to +100 °C baseplate temperature with appropriate power derating. Specifications subject to change without notice.

Parameter	Min.	Typ.	Max.	Units	Notes & Conditions
ABSOLUTE MAXIMUM RATINGS					
Input Voltage					
Non-Operating	-0.5		500	V	Continuous
Operating			425	V	Continuous
Operating Transient Protection			475	V	1 s transient, square wave
Operating Temperature	-55		+100	°C	Baseplate temperature
Storage Temperature	-65		+135	°C	
Voltage at ON/OFF input pin	-2		12	V	
Voltage at Vset and Iset Pins	-0.2		2.5	V	See Note 1
Voltage between Vsense+ and Vout+ pins			±6.0	V	
Voltage between Vsense- and Vout- pins			±0.25	V	
INPUT CHARACTERISTICS					
Operating Input Voltage Range	155	270	425	V	475V transient for 1 s
Input Under-Voltage Turn-On Threshold	146	150	155	V	
Input Under-Voltage Turn-Off Threshold	141	146	151	V	
Input Over-Voltage Turn-Off Threshold	466	485	503	V	
Input Over-Voltage Turn-On Threshold	447	465	484	V	
Recommended External Input Capacitance	15			µF	Typical ESR 1Ω see Note 3
Input Filter Component Values (L\C)		4.7\0.88		µH\µF	Internal values; see Figure F
Maximum Input Current			7.3	A	Vin min; trim up; in current limit
No-Load Input Current; 28Vout		50	85	mA	
Disabled Input Current		1	2	mA	
Response to Input Transient; 28Vout		2		V	See Figure 13
Input Terminal Ripple Current		70		mA	RMS, Full load
Recommended Input Fuse			10	A	Fast acting external fuse recommended
OUTPUT CHARACTERISTICS					
Output Voltage Set Point	10		40	V	
Output Voltage Regulation					
Load Regulation		-2%*Vout*Iout/Imax			
Over Load		±100mV ±2%*Vout + Load Reg			Between Sense Pins, over sample, line, load, temp and life.
Output Voltage Ripple and Noise; 12Vout		75		mV	20 MHz bandwidth pk-pk; see Note 2
Output Voltage Ripple and Noise; 28Vout		150		mV	"
Output Voltage Ripple and Noise; 40Vout		300		mV	"
Operating Output Current Range	0		60	A	Subject to thermal derating and max power. See Note 4.
Output DC Current-Limit Inception		70		A	Output voltage 10% Low
Back-Drive Current Limit while Disabled		0.5		mA	Negative current drawn from output
External Output Capacitance	100			µF	ESR > 1mΩ

Note 1: Vset, Iset, Ishare, Battle Short, Serial In, and Serial Out all referenced to Vsense-.

Note 2: Output is terminated with 1 µF ceramic and 15 µF low-ESR tantalum capacitors. For applications requiring reduced output voltage ripple and noise, consult SynQor applications support (e-mail: mqnbofae@synqor.com)

Note 3: An input capacitor with series resistance is necessary to provide system stability.

Note 4: Unit is rated for 60A max output current or 1000W maximum power. (ie Vout > 16.7V, Iout=1000/Vout)

Technical Specification

MCOTS-C-270-40-FE ELECTRICAL CHARACTERISTICS (continued)

Tb = 25 °C, Vin = 270dc unless otherwise noted; full operating temperature range is -55 °C to +100 °C baseplate temperature with appropriate power derating. Specifications subject to change without notice.

Parameter	Min.	Typ.	Max.	Units	Notes & Conditions
EFFICIENCY					
100% Load; 270 Vin; 12Vout		91.0		%	
100% Load; 270 Vin; 28Vout		92.0		%	
100% Load; 425 Vin; 28Vout		94.5		%	
50% Load; 270 Vin; 12Vout		92.5		%	
50% Load; 270 Vin; 28Vout		93.5		%	
50% Load; 425 Vin; 28Vout		93.5		%	
FEATURE CHARACTERISTICS					
Switching Frequency	255	275	295	kHz	
Synchronization					
Sync Frequency Range	250		300	kHz	
Duty Cycle Range at Input Pin	25		75	%	
Logic Low Threshold Range	0.8	1.2		V	
Logic High Threshold Voltage		1.3	2	V	
Threshold Hysteresis		0.1		V	
Pin Pull-Up Voltage		3.3		V	
Pin Pull-Up Resistance		5		kΩ	
ON/OFF Control					See REMOTE ON/OFF: in CONTROL FEATURES
Off-State Voltage	2.4		12	V	
On-State Voltage	-1		0.8	V	
ON/OFF Control					See Application notes Figures A & B
Input Resistance		3		kΩ	
Output Voltage Setpoint					See OUTPUT VOLTAGE SETPOINT: in CONTROL FEATURES
Pin Pull-Up Voltage		2.5		V	
Pin Pull-Up Resistance		10.9		kΩ	
Output Voltage Setpoint Range	10		40	V	
Output Over-Voltage Shutdown		47		V	Fixed - Does not vary with output setpoint
Output Current Setpoint					See OUTPUT CURRENT SETPOINT: in CONTROL FEATURES
Pin Pull-Up Voltage		2.5		V	
Pin Pull-Up Resistance		10.0		kΩ	
Output Current Setpoint Range	0		60	A	
Output Current Limit	62	68	74	A	See Fig 6
Ishare					See OUTPUT CURRENT SHARE: in CONTROL FEATURES
Pin Voltage at no load		0.2		V	
Pin Voltage at Full Load (Imax)		2.2		V	
Pin Output Resistance		2.5		kΩ	
Over-Temperature Shutdown		130		°C	Average PCB Temperature
Over-Temperature Shutdown Restart Hysteresis		20		°C	

Technical Specification

MCOTS-C-270-40-FE ELECTRICAL CHARACTERISTICS (continued)

Tb = 25 °C, Vin = 270dc unless otherwise noted; full operating temperature range is -55 °C to +100 °C baseplate temperature with appropriate power derating. Specifications subject to change without notice.

Parameter	Min.	Typ.	Max.	Units	Notes & Conditions
DYNAMIC CHARACTERISTICS					
Output Voltage during Load Current Transient					
Step Change in Output Current (0.1 A/μs)		0.75		V	12Vout; 360W to 540W to 360W
Settling Time		200		μs	12Vout; To within 1.5% Vout nom
Step Change in Output Current (0.1 A/μs)		1.5		V	28Vout; 500W to 750W to 500W
Settling Time		300		μs	28Vout; To within 1.5% Vout nom
Turn-On Transient					
Turn-On Time		40		mS	28Vout, Full load, From Enable low to Vout=90% nom.
Start-Up Inhibit Time		250		mS	
Output Voltage rise rate		1.6		V/mS	
Output Voltage Overshoot		0		%	
ISOLATION CHARACTERISTICS					
Isolation Voltage (dielectric strength)					
Input to Output			4250	V dc	
Input to Baseplate			2300	V dc	
Output to Baseplate			2300	V dc	
Isolation Resistance	100			MΩ	
Isolation Capacitance (input to output)		N/A		pF	See Note 5
TEMPERATURE LIMITS FOR DERATING CURVES					
Semiconductor Junction Temperature			125	°C	Package rated to 150 °C
Board Temperature			125	°C	UL rated max operating temp 130 °C
Transformer Temperature			125	°C	
Maximum Baseplate Temperature, Tb			100	°C	
TEMPERATURE LIMITS FOR DERATING CURVES					
Calculated MTBF per MIL-HDBK-217F		1.0		MHrs.	Ground Benign, 70°C Tb
Calculated MTBF per MIL-HDBK-217F		0.3		MHrs.	Ground Mobile, 70°C Tb

Note 5: Input to output isolation capacitance external to the module is recommended.

STANDARDS COMPLIANCE

Parameter	Notes & Conditions
STANDARDS COMPLIANCE	
UL 62368-1	Reinforced Insulation
CAN/CSA-C22.2 No. 62368-1	
EN62368-1	

Note: An external input fuse must always be used to meet these safety requirements. Contact SynQor for official safety certificates on new releases or download from the SynQor website.

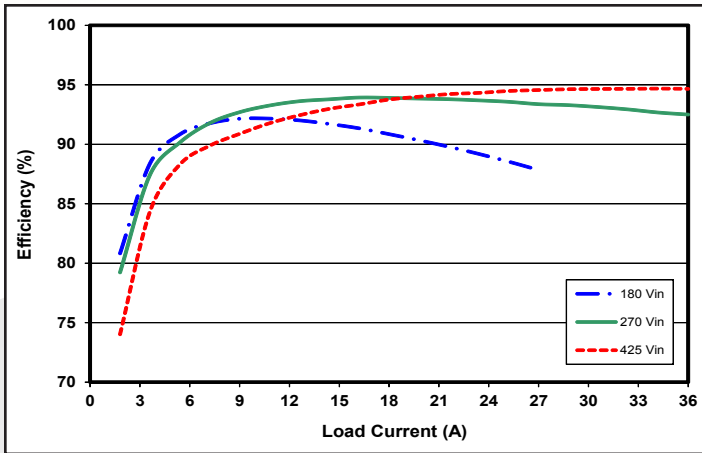

Figure 1: Efficiency at nominal output voltage (28V) vs. load current for three input voltages at 25°C.

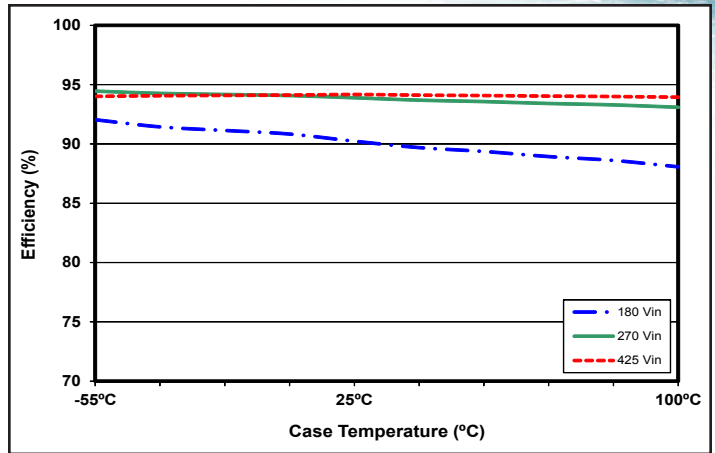

Figure 2: Efficiency at nominal output voltage (28V) and 60% rated power vs. case temperature for three input voltages.

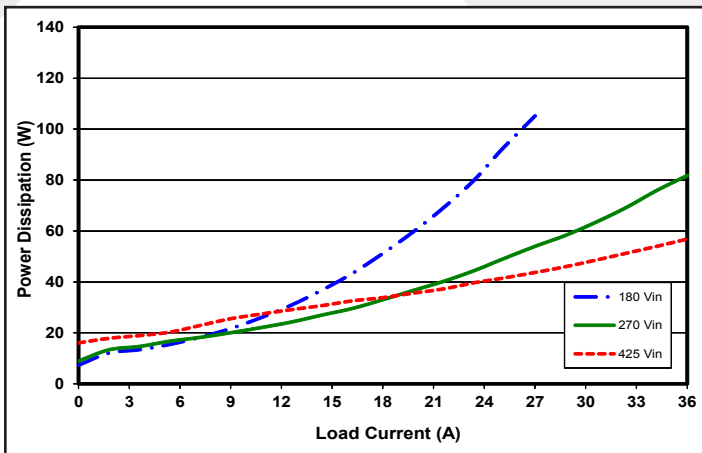

Figure 3: Power dissipation at nominal output voltage (28V) vs. load current for three input voltages at TCASE=25°C.

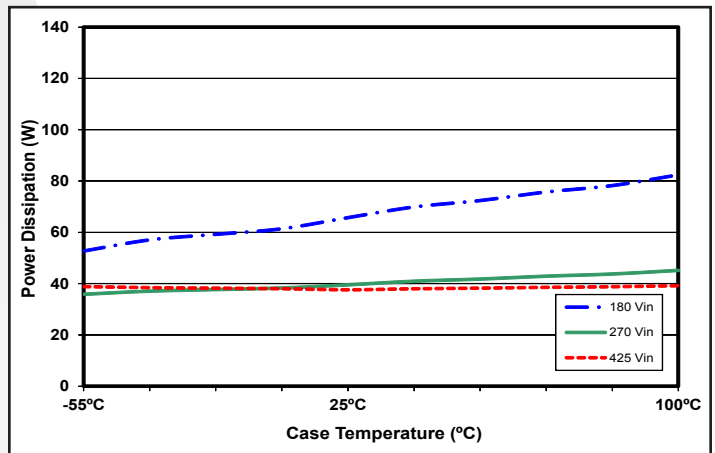

Figure 4: Power dissipation at nominal output voltage (28V) and 60% rated power vs. case temperature for three input voltages.

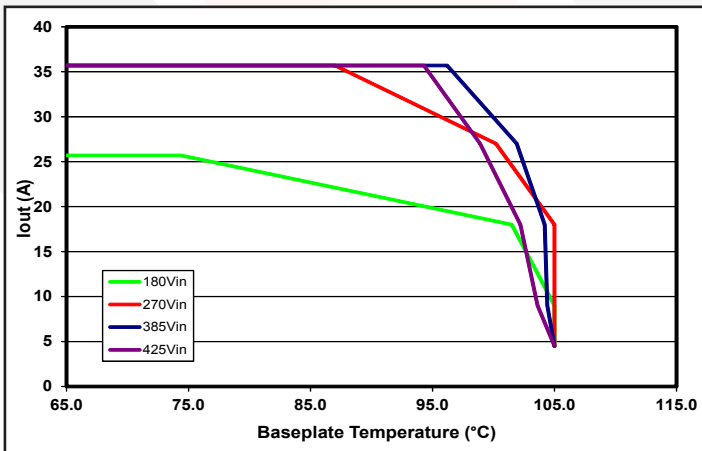

Figure 5: Maximum output current vs. base plate temperature (nominal output voltage).

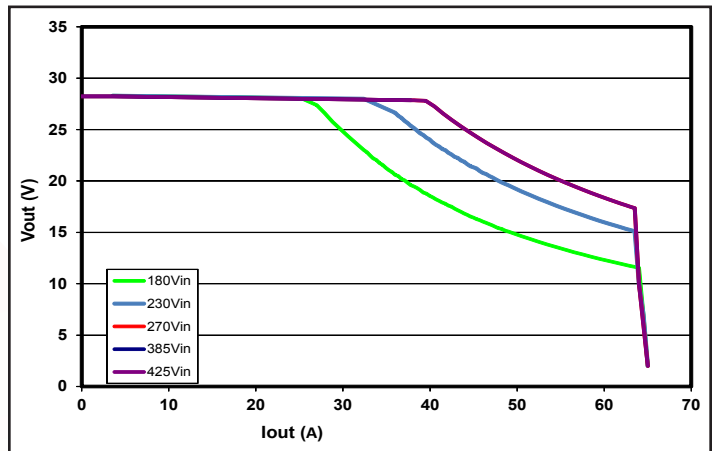

Figure 6: Output voltage vs. load current showing typical current limit curves. See Current Limit section in the Application Notes.

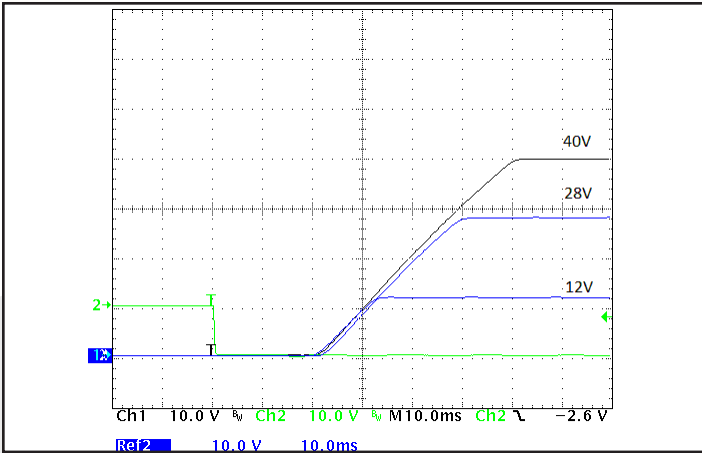

Figure 7: Typical Startup Waveform. Input voltage pre-applied, ON/OFF Pin on Ch 2. Output Capacitance 1mF. Ch 1: Vout (10V/div), Ch 2: ON/OFF Pin (10V/div), Time (10ms/div).

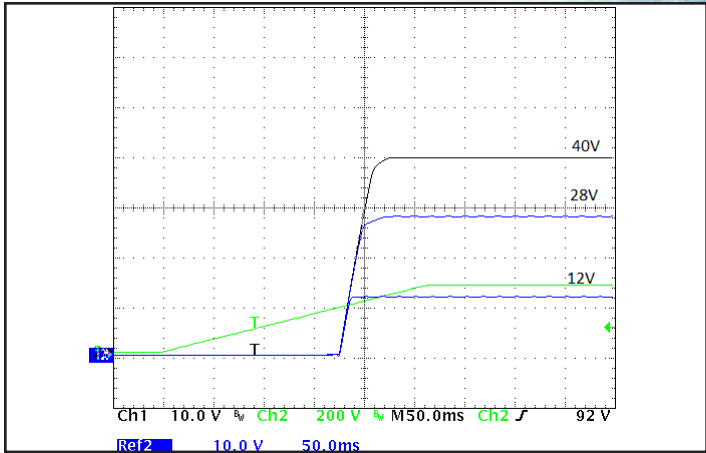

Figure 8: Turn-on Transient at full resistive load and zero output capacitance initiated by Vin. ON/OFF Pin previously low. Ch 1: Vout (10V/div), Ch 2: Vin (200V/div), Time (50ms/div).

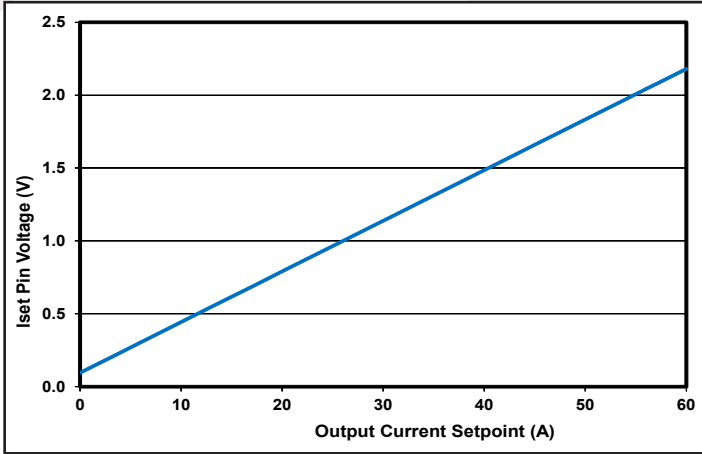

Figure 9: Iset pin voltage vs. Output Current Limit Setpoint.

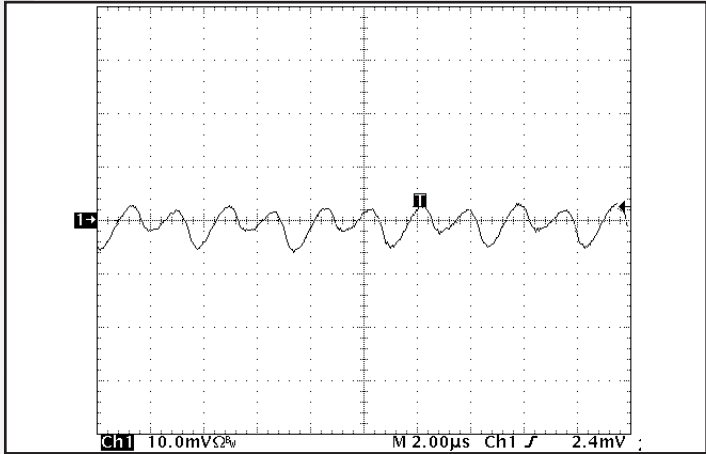

Figure 10: Input Terminal Current Ripple, i_c , at full rated output current and nominal input voltage. Bandwidth: 2MHz. See Figure 17. Ch 1: i_c (200mA/div), Time (2µs/div).

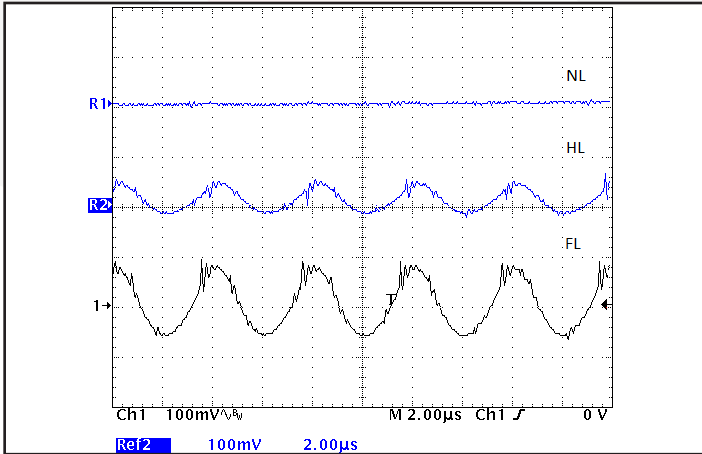

Figure 11: Output Voltage Ripple, 28Vout, at nominal input voltage and rated load current. Load capacitance: 1µF ceramic capacitor and 15µF tantalum capacitor. Bandwidth: 10MHz. See Figure 17. Ch 1: Vout (100mV/div), Time (2µs/div).

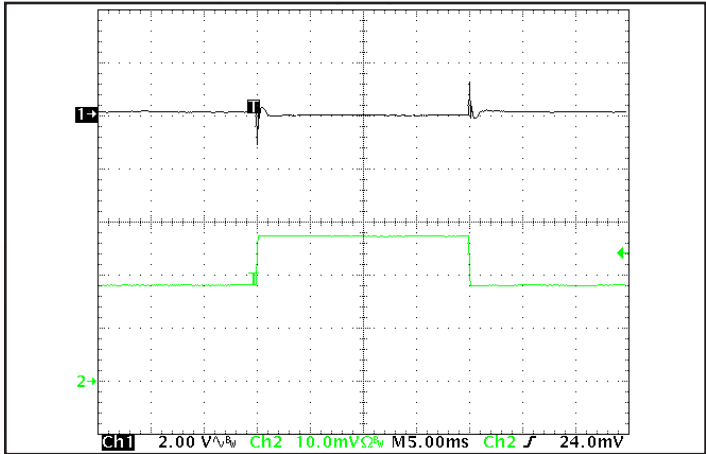

Figure 12: Output voltage response to step-change in load current (500W-750W-500W; $dI/dt = 0.1A/\mu S$). Load cap: 1µF ceramic and 15µF tantalum capacitors. Ch 1: Vout (2V/div), Ch 2: Iout (10A/div), Time (ms/div).

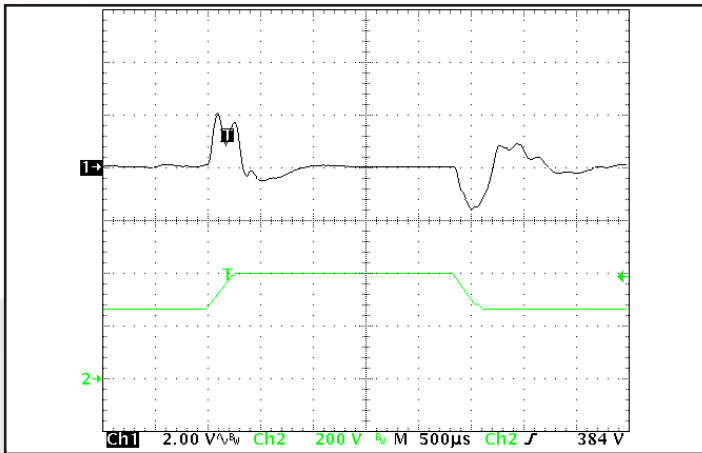

Figure 13: Output voltage response to step-change in input voltage (250V/ms). Load cap: 100 µF electrolytic output capacitance. Ch 1: Vout (2V/div), Ch 2: Vin (200V/div). Time (500µs/div).

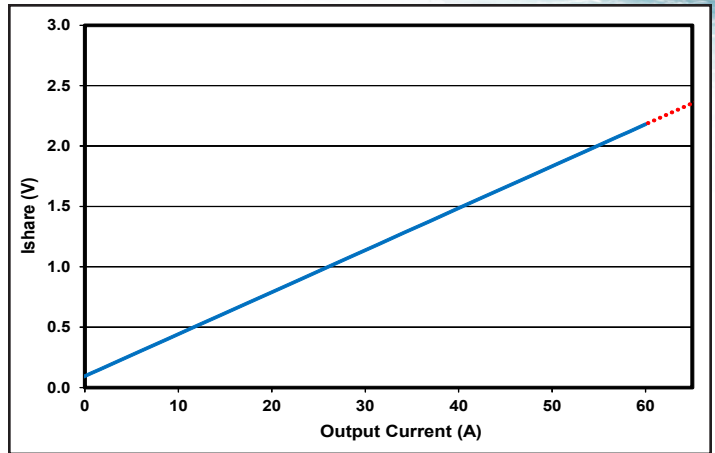

Figure 14: Ishare pin Voltage vs Output Load Current.

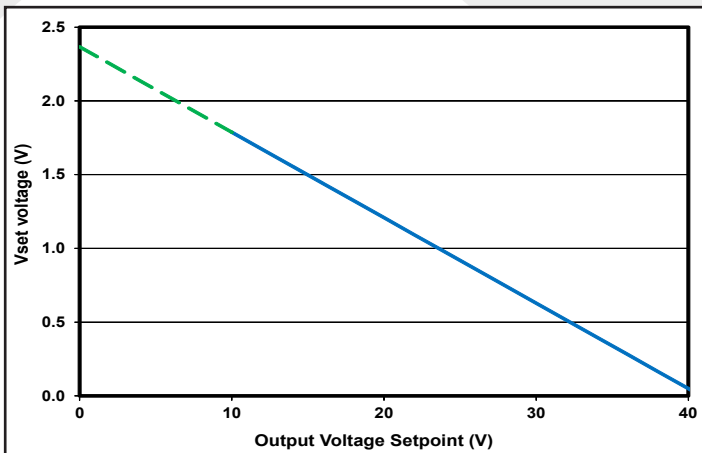

Figure 15: Vset pin voltage vs Output Voltage Setpoint.

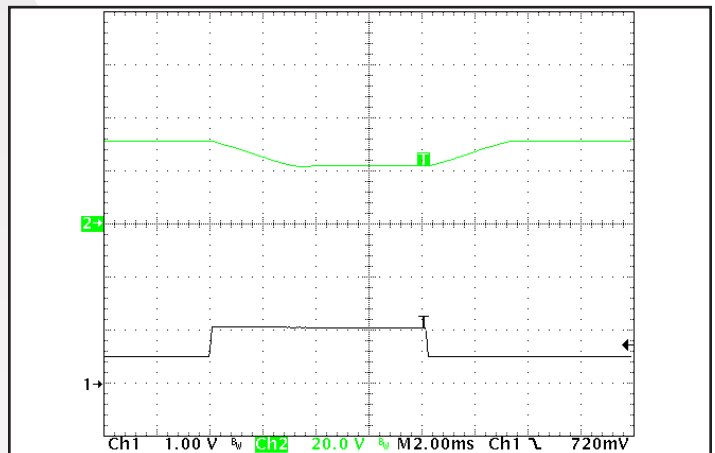

Figure 16: Output Voltage vs. Vset pin voltage dynamics: 270Vin, 10A out. Ch 1: Vset pin voltage (1V/div), Ch 2: Output voltage (20V/div), Time (2mS/div).

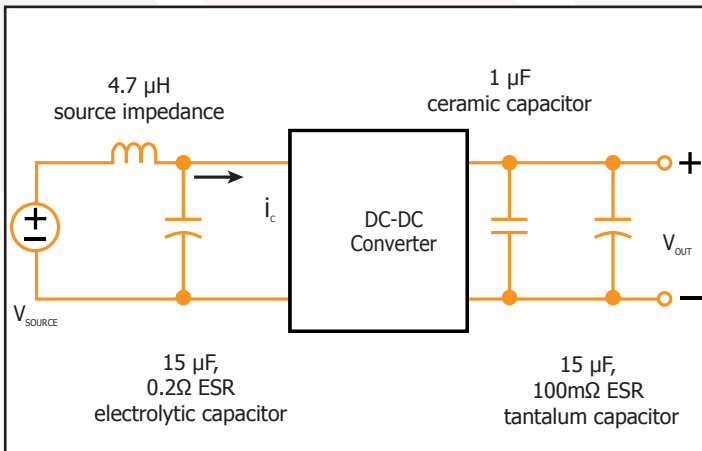

Figure 17: Test set-up diagram showing measurement points for Input Terminal Ripple Current (Figure 10) and Output Voltage Ripple (Figure 11).

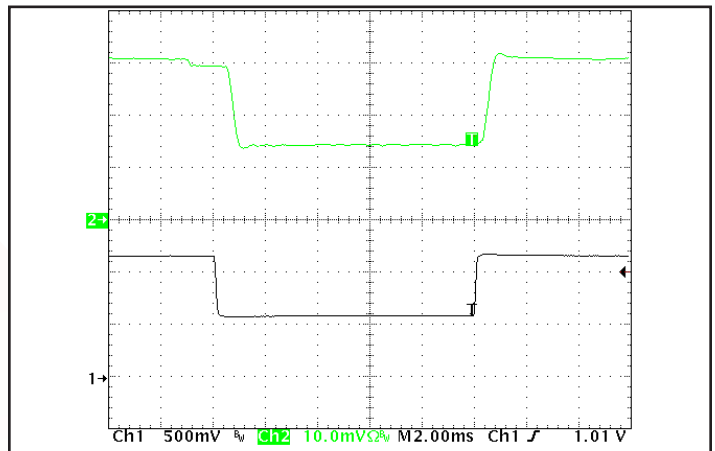

Figure 18: Output Current vs. Iset pin voltage dynamics: 270Vin, 10Vout. Ch 1: Iset pin voltage (500mV/div), Ch 2: Output Current (10A/div), Time (2mS/div).

BASIC OPERATION AND FEATURES

This Mil-COTS converter series uses a two-stage power conversion topology. The first stage is a bus-converter that provides input/output isolation and voltage step down. The second stage consists of an integrated buck and boost converter that regulates the output voltage over variations in line, load and temperature.

Both the first stage and the second stage switch at a fixed frequency for predictable EMI performance. The switching frequency of second stage is half of the switching frequency of first stage and is locked in phase. All rectification is accomplished with synchronous rectifiers. These devices, which are MOSFETs with a very low on-state resistance, dissipate far less energy than Schottky diodes. This is the primary reason that the converter has such high efficiency, even at very low output voltages and very high output currents.

These converters are offered totally encased to withstand harsh environments and thermally demanding applications. Dissipation throughout the converter is so low that it does not require a heatsink for operation in many applications; however, adding a heatsink provides improved thermal derating performance in extreme situations.

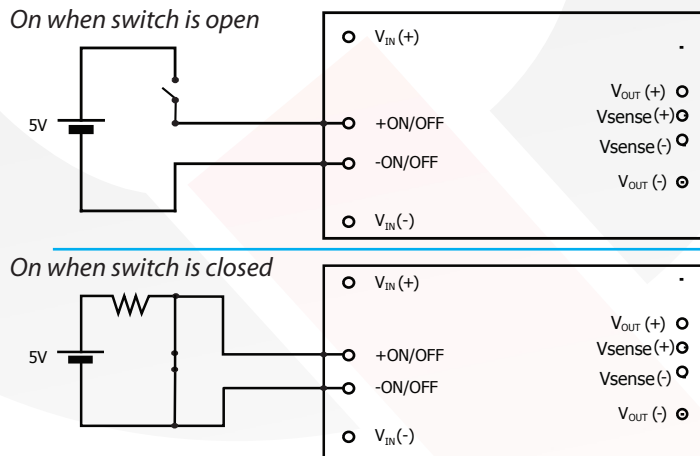

Figure A: Example of two configurations for the enable signal

CONTROL FEATURES

ON/OFF(+) AND ON/OFF(-) (PIN 3 AND 4) - REMOTE

ON/OFF: The ON/OFF inputs, Pins 3 and 4, permit the user to turn the converter on or off. These two inputs are fully isolated from both the input and the output side of the power converter, allowing the user the option to manage the converter from the input or the output end. The user's on/off control signal is applied between the ON/OFF(+) pin and the ON/OFF(-) pins. Figure A details two possible circuits for driving the ON/OFF pin. Figure B is a detailed look of the internal ON/OFF circuitry.

REMOTE SENSE(+) AND SENSE(-) (PINS A7 AND A9):

The sense inputs correct for voltage drops along the conductors that connect the converter's output pins to the load. Pin A7 should be connected to $V_{out}(+)$ and Pin A9 should be connected to $V_{out}(-)$ at the point on the board where regulation is desired. A remote connection at the load can adjust for a voltage drop only as large as that specified in this datasheet. Please see limits in ABSOLUTE MAXIMUM RATINGS in Electrical Characteristics section of the datasheet.

Pins A7 and A9 must be connected for proper regulation of the output voltage. If these connections are not made, the converter will deliver an output voltage that is slightly higher than its set value.

The voltage at the output terminals of the module will be trimmed up by the control circuit to compensate for voltage drops between the output pins of the module and the remote sense point. Note that the over-voltage protection (OVP) circuit senses the voltage at the output pins of the module. It is possible to inadvertently trip the OVP protection circuit if the voltage drop between the output pins and the sense point becomes too large. Hence, the remote sensing feature should be used only to compensate for small values of voltage drops to avoid triggering OVP due to a line or load transient.

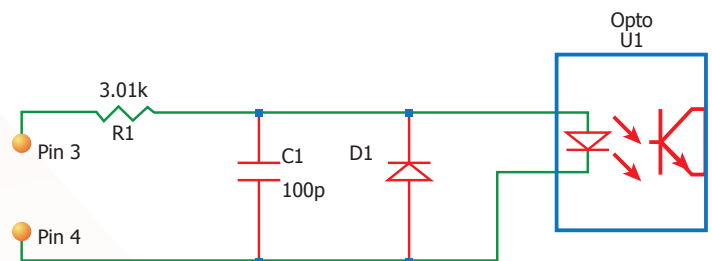

Figure B: Internal ON/OFF pin circuitry

Technical Specification

OUTPUT VOLTAGE SETPOINT: The output voltage can be programmed to any voltage between 0Vdc and Vmax by connecting one resistor between Vset pin (A1) and Vsense- (A9); For a desired output voltage, the value of the resistor.

$$RV_{set}(V_{set}) = \left[\left(\frac{11830 \times V_{max}}{V_{set} + 0.058 \times V_{max}} \right) - 10912 \right] (\Omega)$$

Alternatively, the Vset pin can be driven from an external voltage source: Undriven, this pin floats at 2.5V which sets the output to 0V. See Figure 16 for the large scale dynamics of this input.

$$V_{vset}(V_{set}) = 2.366 - 2.316 \left(\frac{V_{set}}{V_{max}} \right) V$$

See Figure 15

Where:

Vset = desired output voltage setpoint
Vmax = maximum rated output voltage (40V)

OUTPUT CURRENT SETPOINT: The maximum output current (effectively the current limit) can be reduced to any value between 0 and Imax by connecting one resistor between the Iset pin (A10) and Vsense- (A9); see Figure C. The value of the resistor should be:

$$RI_{set}(I_{set}) = \left[\left(\frac{0.0469 I_{max} + I_{set}}{1.153 I_{max} - I_{set}} \right) * 10200 - 10 \right] (\Omega)$$

Alternatively, the Iset pin can be driven from an external voltage source:

$$VI_{set}(I_{set}) = \left(0.0953 + 2.085 * I_{set}/I_{max} \right) V$$

Where:

Iset = desired output current setpoint
Imax = maximum rated output current (60A)

Undriven, the Iset pin floats to 2.5V which sets the current limit at its nominal value of 115%*Imax. See Figure 18 for the large signal dynamics of this control.

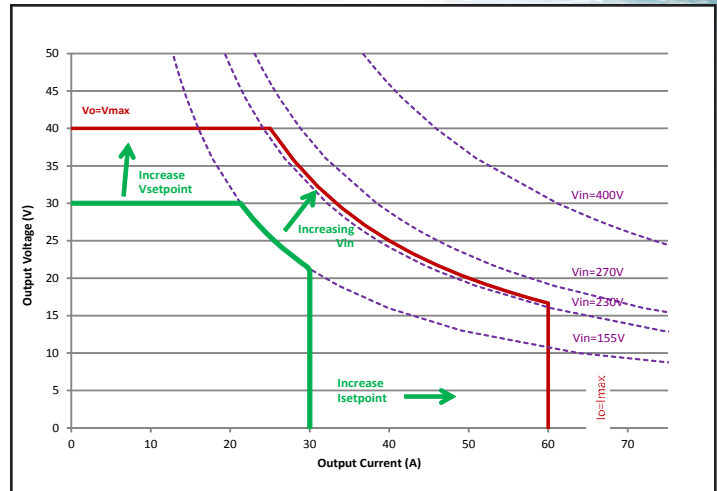

Figure C: Trim graph for trim-up, trim down.

It is not necessary for the user to add capacitance at the Trim pin. The node is internally bypassed to eliminate noise.

TOTAL DC VARIATION OF VOUT: For the converter to meet its full specifications, the maximum variation of the dc value of VOUT, due to remote load voltage drops and transients, should not be greater than that specified for the max over voltage protection.

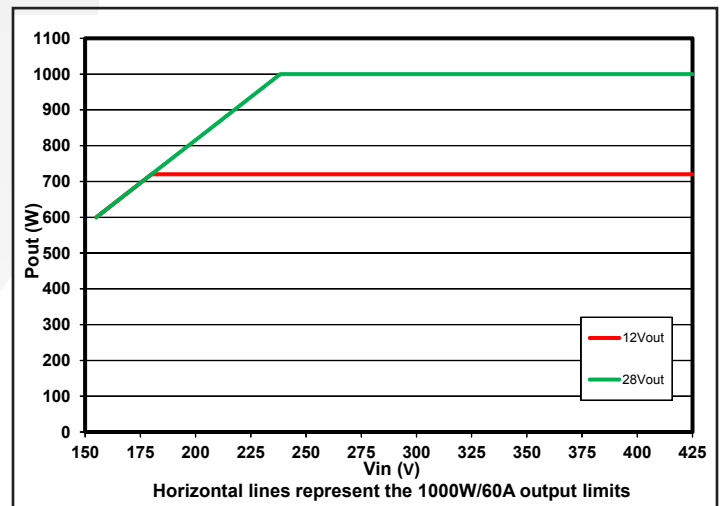

Figure D: Vin vs Pout available.

AVAILABLE OUTPUT POWER: The FE output power can be limited by several means. Typically at lower lines, the available output power is a function of the maximum input current that the integrated Buck/Boost can deliver. At higher lines, the output power will be limited by the lesser of 1000W or Imax. Thermal considerations may affect maximum deliverable power. See Figures 5 and D.

Technical Specification

PROTECTION FEATURES

INPUT UNDER-VOLTAGE LOCKOUT: The converter is designed to turn off when the input voltage is too low, helping avoid an input system instability problem, described in more detail in the application note titled "Input System Instability" available on www.SynQor.com. The lockout circuitry is a comparator with DC hysteresis. When the input voltage is rising, it must exceed the typical Turn-On Voltage Threshold value (listed on the specification page) before the converter will turn on. Once the converter is on, the input voltage must fall below the typical Turn-Off Voltage Threshold value before the converter will turn off.

OUTPUT OVER-VOLTAGE LIMIT: If the voltage across the output pins exceeds $\sim 110\%$ of V_{max} , the converter will immediately stop switching and waits an inhibit time ($\sim 100\text{mS}$), and then tries to restart.

INPUT OVER-VOLTAGE PROTECTION: The converter includes two stage over-voltage feature that limits the converter's duty cycle for 100mS before shutdown when input voltage is below the max transient voltage with load greater than 35W and an automatic shutdown with no delay when above the max transient voltage (See the Input Over-Voltage Shutdown section in the Electrical Characteristics Table for specific voltage levels). It also has a hysteresis and time delay to ensure proper operation.

OVER-TEMPERATURE SHUTDOWN: Several temperature sensors on the converter sense the average temperatures of the module. The thermal shutdown circuit is designed to turn the converter off when the temperature at the sensed location reaches the Over-Temperature Shutdown value. It will allow the converter to turn on again when the temperature of the sensed location falls by the amount of the Over-Temperature Shutdown Restart Hysteresis value.

OUTPUT CURRENT LIMIT/SHUTDOWN: To provide protection in an output short condition, the unit is equipped with internal short circuit protection. When the short-circuit protection is triggered, the converter shuts down and then waits an inhibit time ($\sim 100\text{mS}$), after which it tries to turn on again. If the short circuit remains, the current limit circuit will limit the output current. The unit will return to normal operation once the fault is removed.

Technical Specification

APPLICATION CONSIDERATIONS

INPUT SYSTEM INSTABILITY: This condition can occur because any DC-DC converter appears incrementally as a negative resistance load. A detailed application note titled "Input System Instability" is available on the SynQor website which provides an understanding of why this instability arises, and shows the preferred solution for correcting it. See: www.synqor.com/documents/appnotes/appnt_System_Instability.pdf

APPLICATION CIRCUITS: Figure E provides a typical circuit diagram which details the input filtering and voltage trimming.

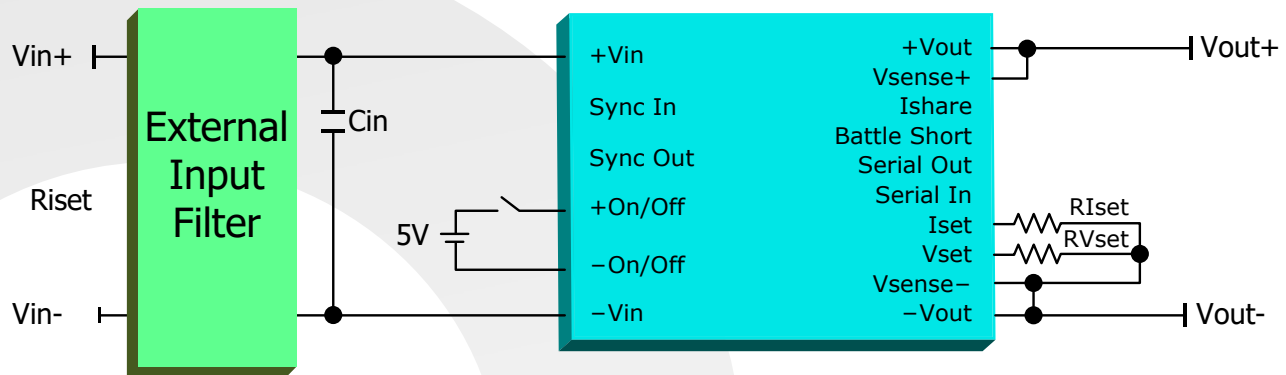

Figure E: Typical application circuit (negative logic unit, permanently enabled).

INPUT FILTERING AND EXTERNAL CAPACITANCE: Figure F provides a diagram showing the internal input filter components. This filter dramatically reduces input terminal ripple current, which otherwise could exceed the rating of the converter's external electrolytic input capacitor. The recommended external input capacitance is specified in the Input Characteristics section on the Electrical Characteristics page. More detailed information is available in the application note titled "EMI Characteristics" on the SynQor website.

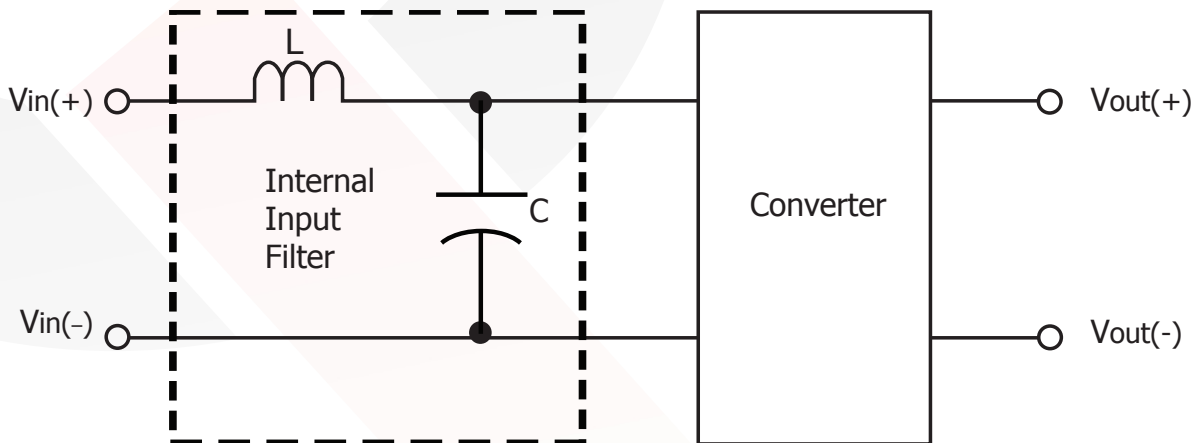

Figure F: Internal Input Filter Diagram (Component values listed in Electrical Characteristics)

Technical Specification

SERIAL IN (PIN A8): A wide variety of operating parameters (voltages, currents, temperatures) may be accessed via the built-in full-duplex asynchronous serial interface. Commands may be transferred to the internal DSP via the SERIAL IN pin at 9600 baud (8N1 - 8 data bits, no parity, 1 stop bit). A 'start' or 'zero' bit is encoded as a logic low. The internal baud rate will be 57.29 times slower than the SYNC OUT frequency.

The SERIAL IN pin may be left open if unused, and will be internally pulled up to 3.3V, corresponding to the 'idle' or 'stop' state. Internal circuitry is shown in Fig G. Direct connection may be made to an external microcontroller, but an external transceiver IC is required to shift levels and polarity to drive form a standard RS-232 port. Safety isolation may be achieved using just one external digital isolator channel since there is no clock signal and the input/output direction is well defined. See the separate "MCOTS-C-270-xx-FE Serial Interface" companion document for detailed command syntax, available at: www.synqor.com/pdf/MCOTS-C-270-xx-FE_Serial_Interface.pdf.

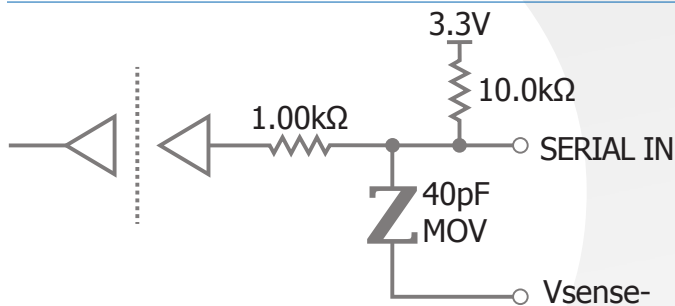

Figure G: Internal circuitry for SERIAL IN pin.

SERIAL OUT (PIN A6): A response to each command is sent via the SERIAL OUT pin at 9600 baud (8N1 - 8 databits, no parity, 1 stop bit). The output is low for a 'start' or 'zero' bit. When not transmitting, the output is high, corresponding to the 'stop' or 'idle' state. Internal circuitry is shown in Figure H. Direct connection may be made to an external microcontroller, but an external transceiver IC is required to shift the levels and polarity to drive a standard RS-232 port.

The SERIAL OUT signals may be combined using an external AND gate. Alternatively, a multi-drop bus may be formed by pulling the bus low when SERIAL OUT is low, and releasing the bus when SERIAL OUT is high, returning the bus to the idle state via a pull-up resistor. The time constant of this pull-up resistor along with any parasitic capacitance must be shorter than the baud rate.

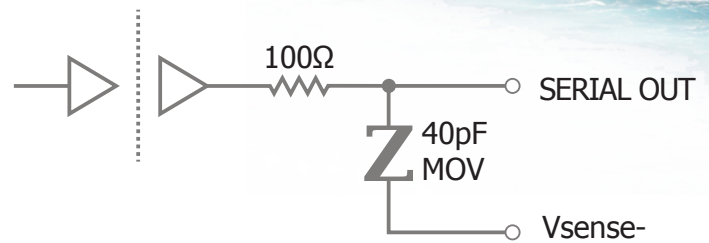

Figure H: Internal circuitry for SERIAL OUT pin.

BATTLE SHORT (PIN A3): If the BATTLE SHORT pin is externally pulled down to Vsense-, over-temperature protection shutdown will be disabled. If the BATTLE SHORT pin is not held externally low, the pin will go high to warn of an impending over-temperature shutdown. The over-temperature warning engages 5 C below shutdown. A 10.0 K pull-up resistor is connected internally to 3.3 V. Internal interface circuitry is shown in Figure I.

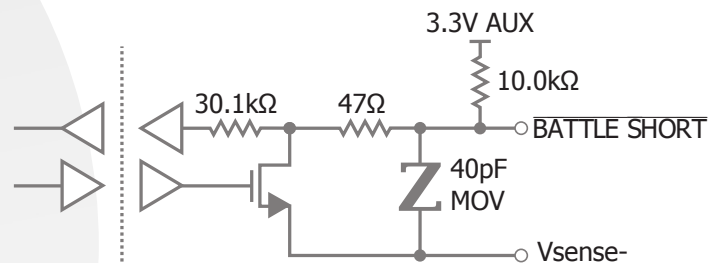

Figure I

BATTLE SHORT pins should not be interconnected between units. When not warning of an impending shutdown the BATTLE SHORT pin is normally pulled low, and this could erroneously cause other units to enter the Battle-short state. If the BATTLE SHORT protection warning output function is used in a paralleled system, then individual signals should be combined using an OR gate. If the BATTLE SHORT protection-disable input function is used in a paralleled system, then either a separate pull-down transistor should be used for each unit, or the Battle-short function may be accessed via the serial port. If a BATTLE SHORT pin is not used, it may be left open.

Technical Specification

All units in this product family include back-drive protection to simplify the use of multiple converters in a parallel or sequencing application. However, any voltage applied to the output of the converter should be kept below the rated output voltage of the converter.

In addition to back-drive protection, these units include the following features (pins):

I SHARE (PIN A2)-ACTIVE CURRENT SHARE: Some applications benefit from connecting the outputs of multiple converters in parallel. Typical applications include systems that require power levels higher than the rated power of one converter, or systems that require N+1 (less than

30) redundancy for increased reliability and availability. The active current share feature of this converter is a secondary side referenced circuit that ensures that modules configured to operate in parallel will share load current to a significant degree ($\pm 2.5\%$ typical at full rated current). This feature is implemented by directly connecting the I share pins of multiple units together. Note also that it is important to connect the Vsense(+) and Vsense(-) pins of each of the parallel modules in the same physical location to ensure the most accurate level of current sharing. The voltage at the I Share pin will range from approximately 0.2 volt (at no load) to 2.2 volts (at full rated current), referenced to the secondary-side ground, Vsense(-). For best performance in current shared mode, the following connections must be implemented:

- I share pins of multiple units must be connected together.
- Vsense(+) and Vsense(-) pins of each module must be tied together at the same physical location, preferably at the end of power out cable or trace.

SYNCIN(PIN1) – EXTERNAL CLOCK SYNCHRONIZATION:

The Clock Synchronization is a primary side referenced feature which allows the user to control the EMI signature and synchronize sensitive circuitry to quiet periods in the converter operation. With this option, the converter can be synchronized to an external clock signal whose frequency is within the limits specified in the Electrical Characteristics Table. Note that increasing the converter's frequency will tend to reduce efficiency.

The Clock Synchronization feature allows the user the following choices:

- Change the switching frequency of the converter from the factory pre-set value to any other value in the specified range.
- Synchronize the switching of all converters in a current shared mode to a common external frequency.
- Improve susceptibility of an adjacent sensitive circuit by moving the converter frequency away from its most sensitive frequency. All the above are also effective means of designing and managing EMI filtering to comply with the specified EMC standards.
- All synchronization signals (including an external clock) should be referenced to the negative terminal of input voltage, Vin(-).
- The high level of the signal should be between 3.5V and 5.0V.
- The low level should be between -0.5V and +1.2V.
- The duty cycle of a signal applied to the SyncIn pin should be between 25% and 75%.

SYNCOUT (PIN2) - SYNCHRONIZATION OUTPUT:

The Synchronization Output is a primary side referenced feature which provides the ability for a user to access a waveform switching synchronously with the pulse width modulator (pwm) clock of the module. The SyncOut signal of one module can be used as the input to multiple other modules.

Technical Specification

STARTUP INHIBIT PERIOD: The Startup Inhibit Period ensures that the converter will remain off for approximately 100 ms when it is shut down for any reason. In all, there are seven ways that the converter can be shut down, initiating a Startup Inhibit Period:

- Input Under-Voltage Lockout
- Input Over-Voltage Lockout
- Output Over-Voltage Protection
- Over Temperature Shutdown
- Current Limit
- Short Circuit Protection
- Turned off by the ON/OFF input

Figure J shows three turn-on scenarios, where a Startup Inhibit Period is initiated at t_0 , t_1 , and t_2 :

Before time t_0 , when the input voltage is below the UVL threshold, the unit is disabled by the Input Under-Voltage Lockout feature. When the input voltage rises above the UVL threshold, the Input Under-Voltage lockout is released, and a Startup Inhibit Period is initiated. At the end of this delay, the ON/OFF pin is evaluated, and since it is active, the unit turns on.

At time t_1 , the unit is disabled by the ON/OFF pin, and it cannot be enabled again until the Startup Inhibit Period has elapsed.

THERMAL CONSIDERATIONS: The maximum operating base-plate temperature, T_B , is 100 °C. Refer to the thermal derating curve figure to see the available output current at baseplate temperatures below 100 °C.

A power derating curve can be calculated for any heatsink that is attached to the base-plate of the converter. It is only necessary to determine the thermal resistance, $R_{TH_{BA}}$, of the chosen heatsink between the base-plate and the ambient air for a given airflow rate. This information is usually available from the heatsink vendor. The following formula can then be used to determine the maximum power the converter can dissipate for a given thermal condition:

$$P_{diss}^{max} = \frac{T_B - T_A}{R_{TH_{BA}}}$$

This value of power dissipation can then be used in conjunction with the data shown in Figure 3 to determine the maximum load current (and power) that the converter can deliver in the given thermal condition.

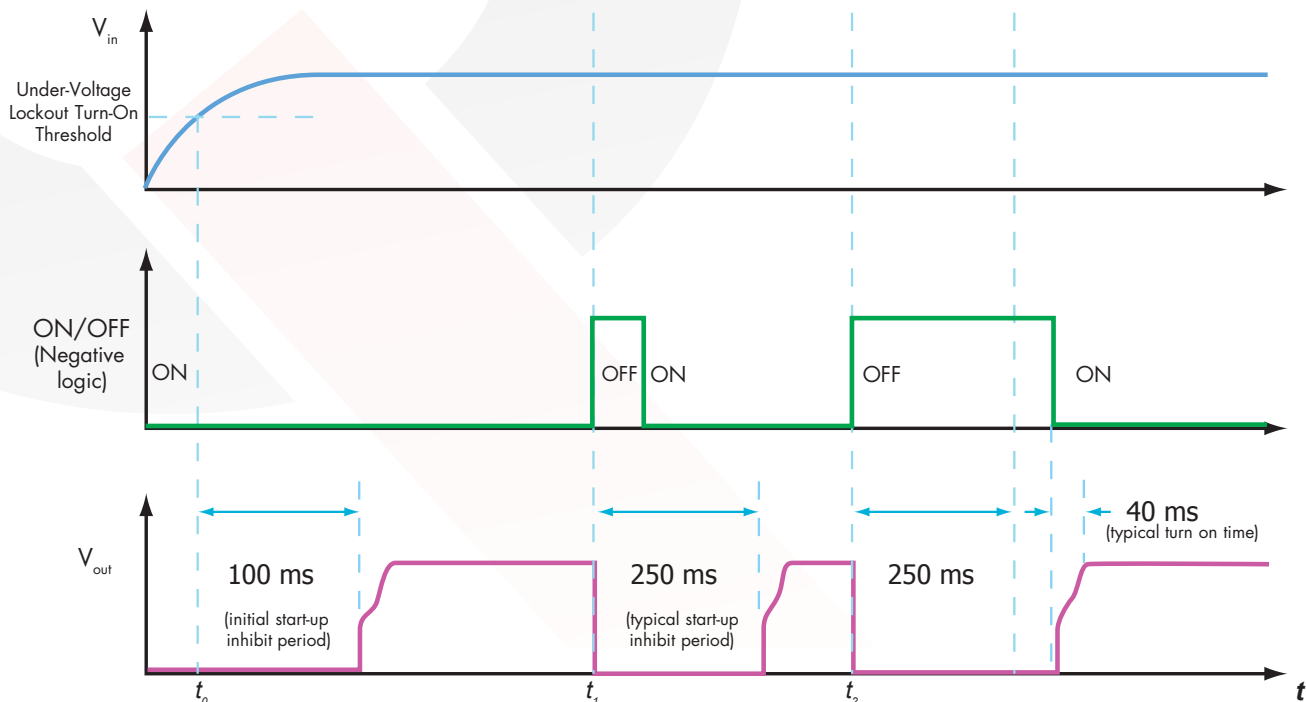
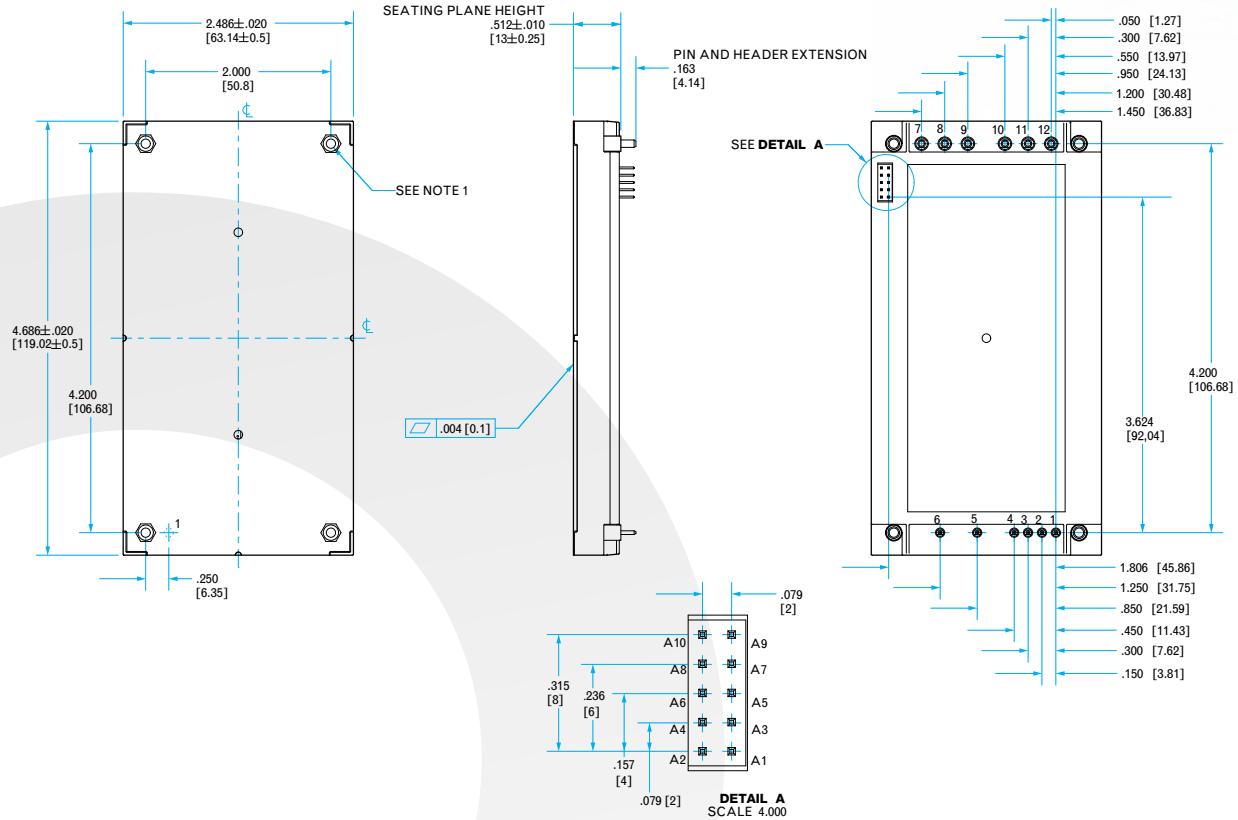

Figure J: Startup Inhibit Period (turn-on time not to scale)

Technical Specification



NOTES

- 1) THREADED: APPLIED TORQUE PER M3 SCREW SHOULD NOT EXCEED 6 in-lb (0.7 Nm)
 NONTHREADED: DIA 0.125" (3.18mm)
- 2) PINS 1-6 ARE 0.040" (1.01 mm) DIA. WITH 0.08" (2.03 mm) DIA. STANDOFF SHOULDERS
 MATERIAL: COPPER ALLOY, FINISH: MATTE TIN OVER NICKEL
- 3) PINS 7-12 ARE 0.080" (2.03 mm) DIA WITH 0.125" (3.175 mm) DIA STANDOFF SHOULDERS
 MATERIAL: COPPER ALLOY, FINISH: MATTE TIN OVER NICKEL
- 4) PINS A1-A10: 0.02" X 0.02" [0.51mm X 0.51mm]
 MATERIAL: PHOSPHOR BRONZE, FINISH: GOLD FLASH OVER NICKEL UNDERPLATING
- 5) Undimensioned components are shown for visual reference only.
- 6) BASEPLATE FLATNESS TOLERANCE IS 0.010" (0.25mm) FOR
- 7) WEIGHT: 10.2oz (289g) TYPICAL
- 8) THREADED OR NON-THREADED OPTIONS AVAILABLE
- 9) WORKMANSHIP: MEETS OR EXCEEDS IPC-A-610 CLASS II
- 10) ALL DIMENSIONS IN INCHES (mm)
 TOLERANCES: X.XX +/-0.02 in. (x.x +/-0.5mm)
 X.XXX +/-0.010 in. (x.xx +/-0.25mm)

PIN DESIGNATIONS

Pin	Label	Name	Function
1	SYNC IN	SyncIn	Synchronization Input
2	SYNC OUT	SyncOut	Synchronization Output
3	+ON/OFF	ON/OFF(+)	Turn converter on and off, referenced to - ON/OFF
4	-ON/OFF	ON/OFF(-)	Fully isolated ground
5	+VIN	Vin(+)	Positive input voltage
6	-VIN	Vin(-)	Negative input voltage
7	-Vout	Vout(-)	Negative output voltage
8	-Vout	Vout(-)	Negative output voltage
9	-Vout	Vout(-)	Negative output voltage
10	+VOUT	Vout(+)	Positive output voltage
11	+VOUT	Vout(+)	Positive output voltage
12	+VOUT	Vout(+)	Positive output voltage
A1	Vset	Vset	Input to set the output voltage
A2	IShare	IShare	Input/Output: Current monitor or Current Share
A3	Battle Short	Battle Short	Pull low to disable OTP
A4	NC	NC	
A5	NC	NC	
A6	Serial Out	Serial Out	Serial Data Output (High = Stop/Idle)
A7	Vsense+	Vsense+	Positive output voltage sense, See Note 2.
A8	Serial In	Serial In	Serial Data Input (High = Stop/Idle)
A9	Vsense-	Vsense-	Negative output voltage sense, See Note 3.
A10	Iset	Iset	Input to set the maximum output current

Pin Designations Notes:

- 1 All control signals referenced to Vsense-.
- 2 Vsense+ should be connected to Vout(+) remotely or at converter.
- 3 Vsense- should be connected to Vout(-) remotely or at converter.

Technical Specification

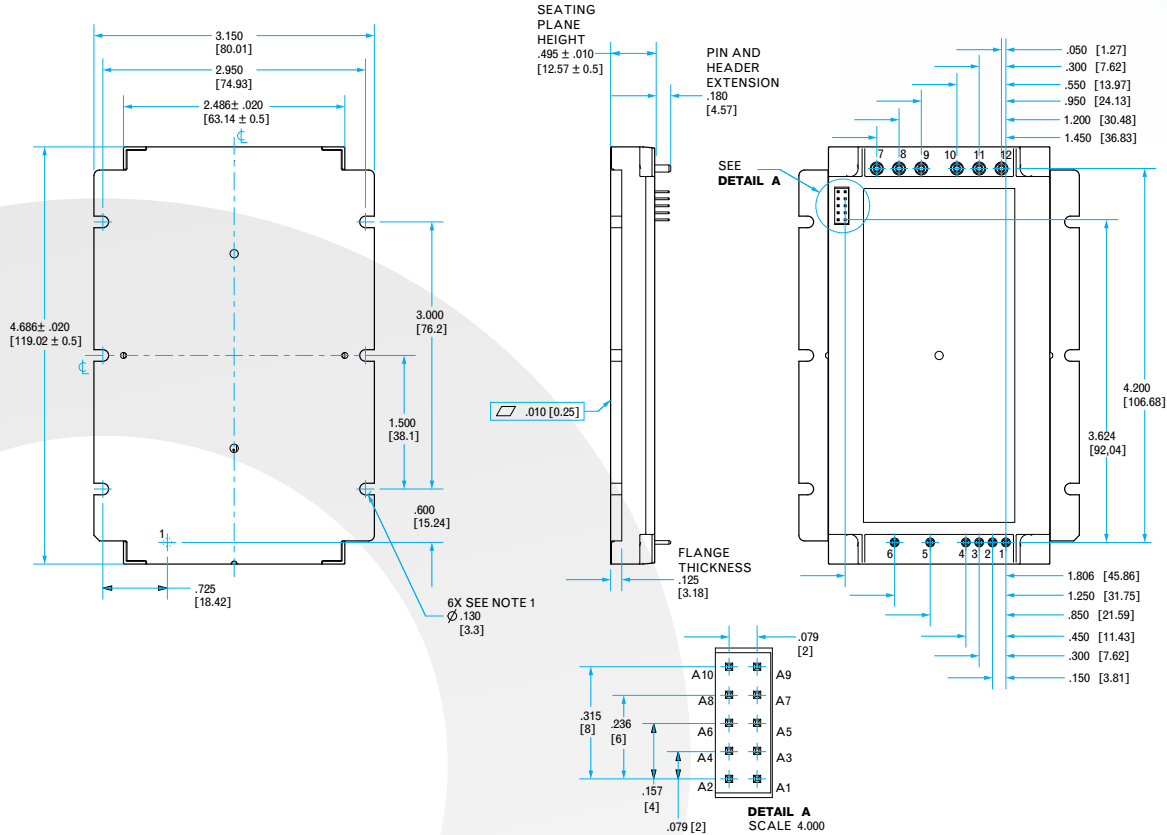

NOTES

- Applied torque per M3 or 4-40 screw should not exceed 6in-lb (0.7Nm).
- Pins 1-6 are 0.040" (1.02mm) diameter, with 0.080" (2.03mm) diameter standoff shoulders.
Material - Copper Alloy; Finish - Matte Tin over Nickel plate
- Pins 7-12 are 0.080" (2.03mm) diameter with 0.125" (3.18mm) diameter standoff shoulders.
Material - Copper Alloy; Finish - Matte Tin over Nickel plate
- Pins A1-A10 are 0.020" (0.51mm) diameter with no standoffs.
Material - Phosphor Bronze; Finish - Gold flash over Nickel plate
- Undimensioned components are shown for visual reference only.
- Baseplate flatness tolerance is 0.010" (.25mm) for surface.
- Weight: 10.6oz (301g) typical
- Workmanship: Meets or exceeds IPC-A-610 Class II
- All dimensions in inches (mm)
Tolerances: x.xx +/-0.02 in. (x.x +/-0.5mm)
x.xxx +/-0.010 in. (x.xx +/-0.25mm)

PIN DESIGNATIONS

Pin	Label	Name	Function
1	SYNC IN	SyncIn	Synchronization Input
2	SYNC OUT	SyncOut	Synchronization Output
3	+ON/OFF	ON/OFF(+)	Turn converter on and off, referenced to - ON/OFF
4	-ON/OFF	ON/OFF(-)	Fully isolated ground
5	+VIN	Vin(+)	Positive input voltage
6	-VIN	Vin(-)	Negative input voltage
7	-Vout	Vout(-)	Negative output voltage
8	-Vout	Vout(-)	Negative output voltage
9	-Vout	Vout(-)	Negative output voltage
10	+VOUT	Vout(+)	Positive output voltage
11	+VOUT	Vout(+)	Positive output voltage
12	+VOUT	Vout(+)	Positive output voltage
A1	Vset	Vset	Input to set the output voltage
A2	IShare	IShare	Input/Output: Current monitor or Current Share
A3	Battle Short	Battle Short	Pull low to disable OTP
A4	NC	NC	
A5	NC	NC	
A6	Serial Out	Serial Out	Serial Data Output (High = Stop/Idle)
A7	Vsense+	Vsense+	Positive output voltage sense, See Note 2.
A8	Serial In	Serial In	Serial Data Input (High = Stop/Idle)
A9	Vsense-	Vsense-	Negative output voltage sense, See Note 3.
A10	Iset	Iset	Input to set the maximum output current

Pin Designations Notes:

- All control signals referenced to Vsense-.
- Vsense+ should be connected to Vout(+) remotely or at converter.
- Vsense- should be connected to Vout(-) remotely or at converter.

Mil-COTS Qualification

Test Name	Details	# Tested (# Failed)	Consistent with MIL-STD-883F Method
Life Testing	Visual, mechanical and electrical testing before, during and after 1000 hour burn-in @ full load	15 (0)	Method 1005.8
Shock-Vibration	Visual, mechanical and electrical testing before, during and after shock and vibration tests	5 (0)	MIL-STD-202, Methods 201A & 213B
Humidity	+85 °C, 95% RH, 1000 hours, 2 minutes on / 6 hours off	8 (0)	Method 1004.7
Temperature Cycling	500 cycles of -55 °C to +100 °C (30 minute dwell at each temperature)	10 (0)	Method 1010.8, Condition A
Solderability	15 pins	15 (0)	Method 2003
DMT	-65 °C to +110 °C across full line and load specifications in 5 °C steps	7 (0)	
Altitude	70,000 feet (21 km), see Note	2 (0)	

Note: A conductive cooling design is generally needed for high altitude applications because of naturally poor convective cooling at rare atmospheres.

Mil-COTS Converter and Filter Screening

Screening	Process Description	S-Grade	M-Grade
Baseplate Operating Temperature		-55 °C to +100 °C	-55 °C to +100 °C
Storage Temperature		-65 °C to +135 °C	-65 °C to +135 °C
Pre-Cap Inspection	IPC-A-610, Class III	•	•
Temperature Cycling	MIL-STD-883F, Method 1010, Condition B, 10 Cycles		•
Burn-In	100 °C Baseplate	12 Hours	96 Hours
Final Electrical Test	100%	25 °C	-55 °C, +25 °C, +100 °C
Final Visual Inspection	MIL-STD-883F, Method 2009	•	•

Mil-COTS MIL-STD-810G Qualification Testing

MIL-STD-810G Test	Method	Description
Fungus	508.6	Table 508.6-I
Altitude	500.5 - Procedure I	Storage: 70,000 ft / 2 hr duration
	500.5 - Procedure II	Operating: 70,000 ft / 2 hr duration; Ambient Temperature
Rapid Decompression	500.5 - Procedure III	Storage: 8,000 ft to 40,000 ft
Acceleration	513.6 - Procedure II	Operating: 15 g
Salt Fog	509.5	Storage
High Temperature	501.5 - Procedure I	Storage: 135 °C / 3 hrs
	501.5 - Procedure II	Operating: 100 °C / 3 hrs
Low Temperature	502.5 - Procedure I	Storage: -65 °C / 4 hrs
	502.5 - Procedure II	Operating: -55 °C / 3 hrs
Temperature Shock	503.5 - Procedure I - C	Storage: -65 °C to 135 °C; 12 cycles
Rain	506.5 - Procedure I	Wind Blown Rain
Immersion	512.5 - Procedure I	Non-Operating
Humidity	507.5 - Procedure II	Aggravated cycle @ 95% RH (Figure 507.5-7 aggravated temp - humidity cycle, 15 cycles)
Random Vibration	514.6 - Procedure I	10 - 2000 Hz, PSD level of 1.5 g ² /Hz (54.6 g _{rms}), duration = 1 hr/axis
Shock	516.6 - Procedure I	20 g peak, 11 ms, Functional Shock (Operating no load) (saw tooth)
	516.6 - Procedure VI	Bench Handling Shock
Sinusoidal vibration	514.6 - Category 14	Rotary wing aircraft - helicopter, 4 hrs/axis, 20 g (sine sweep from 10 - 500 Hz)
Sand and Dust	510.5 - Procedure I	Blowing Dust
	510.5 - Procedure II	Blowing Sand



MCOTS-C-270-40-FE

Output: 10-40V

Current: 60A

Technical Specification

Ordering Information/ Part Numbering

Example MCOTS-C-270-40-FE-N-M

Not all combinations make valid part numbers, please contact SynQor for availability. See the website for details.

Family	Product	Input Voltage	Output Voltage	Package	Heatsink Option	Screening Level	Options
MCOTS	C: Converter	270: 155-425V	40: 10-40V 60: 25-60V	FE: Full Brick Exa	N: Normal Threaded NC: Normal Threaded, with Conformal Coating F: Flanged FC: Flanged, with Conformal Coating D: Normal Non-Threaded DC: Normal Non-Threaded, with Conformal Coating	S: S-Grade M: M-Grade	[]: Standard Feature

APPLICATION NOTES

A variety of application notes and technical white papers can be downloaded in pdf format from our [website](#).

Contact SynQor for further information and to order:

Phone: 978-849-0600

Fax: 978-849-0602

E-mail: power@synqor.com

Web: www.synqor.com

Address: 155 Swanson Road, Boxborough, MA 01719 USA

Warranty

SynQor offers a two (2) year limited warranty. Complete warranty information is listed on our website or is available upon request from SynQor.

PATENTS

SynQor holds numerous U.S. patents, one or more of which apply to most of its power conversion products. Any that apply to the product(s) listed in this document are identified by markings on the product(s) or on internal components of the product(s) in accordance with U.S. patent laws. SynQor's patents include the following:

7,765,687 7,787,261
8,149,597 8,644,027